

INSTALLATION AND OPERATING MANUAL FOR DAB 4" SUBMERSIBLE PUMPS

S41 S42 S43 S44 S46 S48 S412 S416



DAB 4" SUBMERSIBLE PUMP INSTALLATION AND OPERATING INSTRUCTIONS

These instructions supply the necessary information for the installation and operation of 4" submersible pumps, and should be thoroughly read and understood before installation is attempted.

GUARANTEE

The following Guarantee conditions shall apply to borehole submersible pump installation. White International shall not be held responsible for damage caused by improper installation, use of cable and control boxes, level controls or magnetic starters which are not approved by White International, negligent or careless handling, lightning, improper voltage supply, corrosion due to impure water, wear caused by sand, gravel or other abrasives in the water being pumped.

IMPORTANT PRECAUTIONS

1. Damage to pump or motor caused by abrasive or corrosive water is not covered by the Guarantee; however, to guard against installing a pump in aggressive water, it is suggested that an analysis of the bore water be submitted to the Department of Agriculture prior to installation to ensure pump suitability.
2. The bore should be clean before installation. The submersible pump must not be used to bail a new bore. Guarantee does not cover failure or wear due to abrasives in the water.
3. Be sure voltage and frequency as shown on the nameplate of the control box and motor are the same as the voltage and frequency on the line to which the motor is to be connected. Minimum voltage at the motor must be 240 volts for single phase and 415 volts for three phase.
4. Do not allow pump to run single phase unless it is properly connected to the correct control box.
5. Do not allow pumps to run dry, against a closed discharge or full open discharge. Refer to table showing minimum and maximum flow conditions.
6. In addition to the check valve built into the pump, it may be necessary to install an additional check valve. This is mandatory for heads greater than 80 metres, or on pressure systems. This will reduce water hammer shocks to the pump.
7. Know the total depth of the bore and ensure that the pump does not rest on the bottom or in sand. Ensure 2 metres (6 feet) clear below the pump to the bottom of the bore.
8. Know the pumping level of the bore and ensure that the pump remains submerged at all times. Use of level controller is recommended. If probe type is used, the probe should be located to switch the pump off when the bore water level drops within 1 metre of the pump suction. Alternatively a probeless control such as iCON iPROTECT can be used.
9. A Flow Inducer Sleeve or shroud which ensures that the water is drawn into the pump from below the motor is required when the pump is in open water (i.e. water tank, river or dam), in a rock well, below casing or set in screens, or well diameter is too large.
10. Do not install borehole submersibles in a crooked bore without gauging first. Lower a gauge which is the same diameter and length as the pump to be used into the bore. If the gauge does not bind, it is safe to install the pump.

11. Never support the weight of the pump by the drop (power) cable or by the safety rope. Refer instructions in section PUMP DROP PIPE.

TYPICAL SUBMERSIBLE INSTALLATION

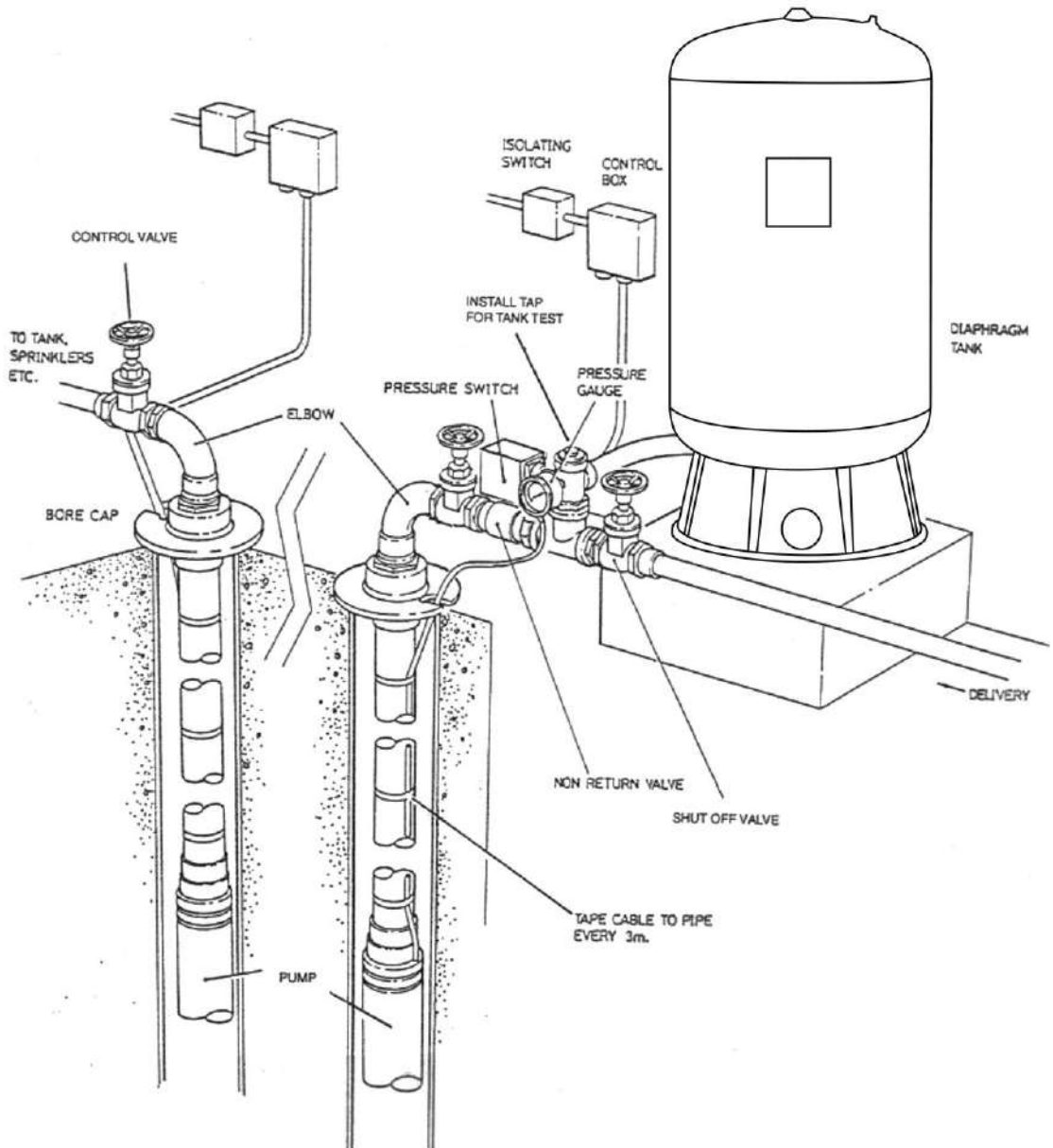

Pump connected for manual operation

Submersible water pressure system incorporating 100 litre pressure tank

DEPTH OF INSTALLATION

Make sure that the unit is at least one metre above any gravel layer and one metre below the minimum drawdown level. If during the initial operation, the pump lowers the well water level until suction is

discontinued, then lower the pump where feasible, or install a protection device, or reduce the flow rate of the pump to prevent over-pumping.

PUMP DROP PIPE (Pipe Down The Bore)

Polythene drop pipe may be used, provided the pressures and depths indicated in the tables below are not exceeded.

| PN RATING | MAX PUMP HEAD (M) BY CURVE | MAX KPA AT TOP OF BORE | MAX PSI AT TOP OF BORE | MAX DEPTH (M) | MAX DEPTH (FT) |
|-----------|----------------------------|------------------------|------------------------|---------------|----------------|
| 6.3 | 63 | 0 | 0 | 63 | 207 |
| 6.3 | 63 | 138 | 20 | 49 | 161 |
| 6.3 | 63 | 276 | 40 | 35 | 114 |
| 6.3 | 63 | 414 | 60 | 21 | 68 |
| 6.3 | 63 | 552 | 80 | 7 | 22 |
| 8 | 80 | 0 | 0 | 80 | 262 |
| 8 | 80 | 138 | 20 | 66 | 216 |
| 8 | 80 | 276 | 40 | 52 | 170 |
| 8 | 80 | 414 | 60 | 38 | 124 |
| 8 | 80 | 552 | 80 | 24 | 78 |
| 8 | 80 | 689 | 100 | 10 | 32 |
| 10 | 100 | 0 | 0 | 100 | 328 |
| 10 | 100 | 138 | 20 | 86 | 282 |
| 10 | 100 | 276 | 40 | 72 | 236 |
| 10 | 100 | 414 | 60 | 58 | 190 |
| 10 | 100 | 552 | 80 | 44 | 144 |
| 10 | 100 | 689 | 100 | 30 | 97 |
| 10 | 100 | 827 | 120 | 16 | 51 |
| 10 | 100 | 965 | 140 | 2 | 5 |
| 12.5 | 125 | 0 | 0 | 125 | 410 |
| 12.5 | 125 | 138 | 20 | 111 | 364 |
| 12.5 | 125 | 276 | 40 | 97 | 318 |
| 12.5 | 125 | 414 | 60 | 83 | 272 |
| 12.5 | 125 | 552 | 80 | 69 | 226 |
| 12.5 | 125 | 689 | 100 | 55 | 179 |
| 12.5 | 125 | 827 | 120 | 41 | 133 |
| 12.5 | 125 | 965 | 140 | 27 | 87 |
| 12.5 | 125 | 1103 | 160 | 13 | 41 |
| 12.5 | 125 | 1172 | 170 | 5 | 18 |
| 16 | 160 | 0 | 0 | 160 | 525 |
| 16 | 160 | 138 | 20 | 146 | 479 |
| 16 | 160 | 276 | 40 | 132 | 433 |
| 16 | 160 | 414 | 60 | 118 | 387 |
| 16 | 160 | 552 | 80 | 104 | 340 |
| 16 | 160 | 689 | 100 | 90 | 294 |
| 16 | 160 | 827 | 120 | 76 | 248 |
| 16 | 160 | 965 | 140 | 62 | 202 |
| 16 | 160 | 1103 | 160 | 48 | 156 |
| 16 | 160 | 1172 | 170 | 40 | 133 |
| 16 | 160 | 1241 | 180 | 33 | 110 |
| 16 | 160 | 1379 | 200 | 19 | 64 |
| 16 | 160 | 1517 | 220 | 5 | 17 |

| PN RATING | MAX PUMP HEAD (M) BY CURVE | MAX KPA AT TOP OF BORE | MAX PSI AT TOP OF BORE | MAX DEPTH (M) | MAX DEPTH (FT) |
|-----------|----------------------------|------------------------|------------------------|---------------|----------------|
| 20 | 200 | 0 | 0 | 200 | 656 |
| 20 | 200 | 138 | 20 | 186 | 610 |
| 20 | 200 | 276 | 40 | 172 | 564 |
| 20 | 200 | 414 | 60 | 158 | 518 |
| 20 | 200 | 552 | 80 | 144 | 472 |
| 20 | 200 | 689 | 100 | 130 | 426 |
| 20 | 200 | 827 | 120 | 116 | 379 |
| 20 | 200 | 965 | 140 | 102 | 333 |
| 20 | 200 | 1103 | 160 | 88 | 287 |
| 20 | 200 | 1172 | 170 | 80 | 264 |
| 20 | 200 | 1241 | 180 | 73 | 241 |
| 20 | 200 | 1379 | 200 | 59 | 195 |
| 20 | 200 | 1517 | 220 | 45 | 149 |
| 20 | 200 | 1655 | 240 | 31 | 103 |
| 20 | 200 | 1793 | 260 | 17 | 56 |
| 20 | 200 | 1931 | 280 | 3 | 10 |

Polythene drop pipe can be selected by reference to the pump curve and its suitability can be checked on site by checking the maximum pressure read at the top of the bore reference to the maximum depth allowed.

An unstrained safety rope must be connected to all pumps suspended on polythene pipe. This line should be fastened to the lifting hook of the pump. The other end should be fastened at the top of the bore casing or bore cap. The safety rope should be affixed at three metre intervals by a suitable underwater tape with the rope having some slackness between each interval to compensate for the expansion of the polythene pipe when under load.

Care should be exercised to ensure that the polythene pipe is securely fastened to reliable fittings.

If galvanized steel drop pipe is used, it is best installed in three meter lengths to enable easy handling and all threads should be treated against corrosion.

It may be necessary, as a safety precaution to install a non-return valve at the top of the bore. This is in addition to the non-return valve fitted in the pump. This will assure a break down of the water hammer and consequently a reduction of shocks on the hydraulic components (which occurs in any pump system) immediately after each shutdown.

This non-return valve is mandatory where the pump heads (pressure at the top of the bore plus pump depth) exceed 80 m (785 kPa or 262 ft) or where the pump is part of an automatic pressure system.

WIRING

Wiring should conform to the requirements of local and national electrical codes. If in any doubt, contact your Electricity Supply Authority.

CAUTION

The use of smaller cable than specified below may cause premature motor failure and will void the warranty. Larger sized cables may be used.

The use of old drop cable or white flat is not recommended. Use water-proof cable only, i.e, Aquaflex AQM rated for immersion to 100 m (500m immersion rated also available) obtainable from White International.

The tables on the next page indicate the correct size electrical drop cable and maximum lengths to be used.

SINGLE PHASE 240 VOLT CABLE SELECTION

| TESLA 240V MOTOR PSC kW (HP) Metric Cable | | 0.37 (0.5) | 0.55 (0.75) | 0.75 (1.0) | 1.1 (1.5) | 1.5 (2.0) | 2.2 (3.0) |
|--|-------------------------|-----------------------|------------------------|-----------------------|----------------------|----------------------|----------------------|
| Stranding | Area mm ² | metres | metres | metres | metres | metres | metres |
| 7/0.50 | 1.5 | 94 | 67 | 49 | 36 | 29 | 19 |
| 7/0.67 | 2.5 | 174 | 123 | 91 | 67 | 53 | 36 |
| 7/0.85 | 4.0 | 279 | 197 | 146 | 106 | 85 | 58 |
| 7/1.04 | 6.0 | 417 | 296 | 218 | 159 | 126 | 87 |
| 7/1.35 | 10 | 701 | 496 | 366 | 268 | 213 | 147 |
| 7/1.70 | 16 | 1117 | 791 | 585 | 426 | 339 | 235 |

THREE PHASE 415 VOLT CABLE SELECTION

| TESLA 415V MOTOR kW (HP) Metric Cable | | 0.37 (0.5) | 0.55 (0.75) | 0.75 (1.0) | 1.1 (1.5) | 1.5 (2.0) | 2.2 (3.0) | 3.0 (4.0) | 4.0 (5.5) | 5.5 (7.5) | 7.5 (10.5) |
|--|-------------------------|-----------------------|------------------------|-----------------------|----------------------|----------------------|----------------------|----------------------|----------------------|----------------------|-----------------------|
| Stranding | Area mm ² | metres | metres | metres | metres | metres | metres | metres | metres | metres | metres |
| 7/0.50 | 1.5 | 267 | 240 | 185 | 133 | 104 | 77 | 55 | 46 | 33 | 27 |
| 7/0.67 | 2.5 | 491 | 442 | 340 | 245 | 192 | 142 | 101 | 84 | 61 | 49 |
| 7/0.85 | 4.0 | 789 | 710 | 546 | 395 | 308 | 229 | 161 | 135 | 98 | 79 |
| 7/1.04 | 6.0 | 1180 | 1062 | 817 | 590 | 462 | 342 | 241 | 202 | 147 | 118 |
| 7/1.35 | 10 | 1982 | 1784 | 1372 | 991 | 775 | 575 | 405 | 339 | 246 | 198 |
| 7/1.70 | 16 | 3158 | 2843 | 2186 | 1579 | 1236 | 917 | 646 | 541 | 392 | 315 |

MOTOR DATA

| TESLA 240V PSC MOTORS | | | | | | | |
|--------------------------|------|-------------------|----------------------|--|--|-----------------|-------------|
| kW | HP | AMPS Full Load | AMPS Locked Rotor | OHMS Run Winding Black to Blue/Grey* | OHMS Start Winding Black to Brown* | CAPACITOR uF | O/LOAD A |
| 0.37 | 0.5 | 3.4 | 9.2 | 8.8 | 18.8 | 16 | 4 |
| 0.55 | 0.75 | 4.8 | 15.8 | 5.6 | 13.5 | 20 | 5 |
| 0.75 | 1.0 | 6.5 | 20.8 | 3.5 | 6.7 | 25 | 7 |
| 1.1 | 1.5 | 8.9 | 32.0 | 2.5 | 5.4 | 35 | 10 |
| 1.5 | 2.0 | 11.2 | 41.4 | 1.9 | 5.0 | 40 | 13 |
| 2.2 | 3.0 | 16.2 | 50.2 | 1.6 | 3.7 | 60 | 20 |

| TESLA 415V MOTORS | | | | |
|----------------------|------|-------------------|----------------------|---------------------------------|
| kW | HP | AMPS Full Load | AMPS Locked Rotor | OHMS Across Any Two Leads |
| 0.37 | 0.5 | 1.8 | 6.8 | 35.0 |
| 0.55 | 0.75 | 2.0 | 8.4 | 25.6 |
| 0.75 | 1.0 | 2.6 | 13.0 | 17.3 |
| 1.1 | 1.5 | 3.6 | 14.8 | 13.0 |
| 1.5 | 2.0 | 4.6 | 19.8 | 8.9 |
| 2.2 | 3.0 | 6.2 | 27.3 | 6.0 |
| 3.0 | 4.0 | 8.8 | 40.5 | 4.2 |
| 4.0 | 5.5 | 10.5 | 58.8 | 3.3 |
| 5.5 | 7.5 | 14.5 | 79.8 | 2.35 |
| 7.5 | 10.0 | 18.1 | 86.9 | 2.0 |

* Resistances taken at motor leads.

CONNECTION TO THREE PHASE STARTERS

A direct on line starter incorporating thermal overload and fuses must be used with all three phase motors, otherwise warranty will be void. Use of non approved fuses may not protect your motor and void warranty.

CHECK ROTATION OF BOTH SINGLE AND THREE PHASE MOTORS

Both single and three phase motors connected to a supply for the first time may rotate in either direction. It is therefore necessary to find out if the motor is rotating in the correct direction. Motor shaft rotates anticlockwise viewed from the lead grommet end. Change rotation by reversing wires.

If rotation is to be checked on the surface, proceed as follows:

Pour clean water into discharge by holding the non-return valve open so that the shaft bearings and the impellers become wet.

Turn on the power switch and check the shaft rotation is correct.

WARNING: *The dry running should not exceed 2 to 3 seconds, otherwise seizing may occur due to inadequate lubrication.*

If the unit is installed in the bore, then the correct direction of rotation is the one that will give maximum head (pressure) at the same capacity.

To correct a reversed rotation, change any two leads (except earth) from the three phase supply at the motor starter. Mark the leads so that the wires will in future be reconnected to the correct terminals of the starter. Single phase motors wired incorrectly can also operate in reverse. Check wiring.

EARTHING SINGLE AND THREE PHASE PUMPS

All Pump motors are equipped with an earth lead which must be connected to the earth of the incoming power supply. Further, control boxes and starters must also be earthed. If Testing or used outside a well, the motor must be connected to the power supply earth lead to prevent a lethal shock hazard.

ELECTRICAL CHECK LIST

It is recommended that where possible, all electrical connections be carried out before delivery to site.

Always check that the motor gland is tight.

Check control boxes, motors and pumps are as ordered and correctly matched.

Check the motor resistances before and after crimping the drop cable to the motor lead, using the charts supplied, and before the water proof heat shrink is applied.

Make sure that the water proof heat shrink is heated sufficiently to cause resin to flow to create a water tight seal.

If possible, it is good to practice run the pump briefly in a container of water (water must be over the suction inlet) to check on operation before installation in the bore.

Drop cable should be affixed at three metre intervals by a suitable underwater tape with the cable having some slackness between each interval to compensate for the expansion of the polythene pipe when under load.

DELIVERY PIPING

Large diameter pipe should be used for long runs to compensate for pressure losses due to friction. Long pipe runs can cause water hammer and damage to pumping systems. Consult your local borehole specialist as additional check valve and water hammer arrestor (pressure tank) may need to be fitted.

PUMP SWITCHING

By Float Switches, Pressure Switches, Timers etc.

(See also section headed "Pressure System Installation")

Provided the switching device used has an adequate current rating, it may be connected directly into the supply line to 240 volt motor control boxes. If the current rating of the switch is not adequate, a starter contactor must be wired into the supply, and the switching device connected to the control circuit of the starter contactor.

In the case of three phase motors, all switching devices should be wired to the control circuit of a suitable starter contactor, and on no account should they be used to directly break the supply circuit to the pump.

NOTE: Any automatic switching of the pump greater than 20 starts per hour will shorten the motor life and may void warranty.

INITIAL STARTING

Before connecting the pump outlet pipe from the bore, bend and gate valve should be screwed into the top of the bore cap as a pump valve.

With the gate valve just slightly open, start the pump.

NEVER START THE PUMP AT FULL FLOW FOR THE FIRST TIME

Immediately the pump has been started, catch some of the discharge water in a large container and allow the solids to settle out. If little or no sand appears, open the gate valve to 1/3 and pump until the water is clean.

For the first 10 to 20 minutes of operation, it is suggested to keep the gate valve only partially open, to maintain a low flow which will prevent turbulence in the well near the pump and possible seizing of the pump due to excessive sand in the water.

If excessive amounts of sand or other solids are being pumped, shut the pump down, and have the bore attended to before restarting the pump.

Submersible pumps are not guaranteed against failure due to pumping sand. Pumping of sand of even very fine small quantities will shorten the effective life of any pump.

NEVER OPEN THE GATE VALVE ABRUPTLY

as this may raise sand and deposits.

The pump should be run for a period of 30 minutes to check that it does not pump the bore dry. This would be obvious by large fluctuations on the pressure gauge and the ammeter as the pump flow surges. Continuing operation in this manner could cause serious damage to the pump and motor due to shock pressures as the pump alternately takes up and loses the hydraulic load. This effect is generally referred to as “snoring”.

If in doubt about the draw down level of the bore, the use of level controller is recommended. If probe type is used, the probe should be located to switch the pump off when the bore water level drops within 1 metre of the pump suction. The use of a high level probe to automatically turn the pump on is not desired, as a rapid cycling of the pump could occur causing severe damage to the unit. Time clock or manual restart is recommended. Alternatively a probeless control such as ICON IPROTECT or TESLA GUARDIAN can be used.

MINIMUM FLOW CONDITIONS

Premature pump failure may result if pumps are continuously run at flow rates less than the following:

| MINIMUM FLOW RATE | | |
|-------------------|-----|------|
| MODEL | LPM | GPM |
| S41 | 5 | 1.1 |
| S42 | 10 | 2.2 |
| S43 | 20 | 4.4 |
| S44 | 30 | 6.6 |
| S46 | 40 | 8.8 |
| S48 | 50 | 11.0 |

| | | |
|------|-----|------|
| S412 | 90 | 19.8 |
| S416 | 160 | 35.2 |

MAXIMUM FLOW CONDITIONS

Premature pump failure may result if pumps are run for more than a short period at flow rates greater than the following:

| MAXIMUM FLOW RATE | | |
|-------------------|-----|------|
| MODEL | LPM | GPM |
| S41 | 25 | 5.5 |
| S42 | 50 | 11.0 |
| S43 | 70 | 15.4 |
| S44 | 90 | 19.8 |
| S46 | 140 | 30.8 |
| S48 | 180 | 39.6 |
| S412 | 240 | 52.8 |
| S416 | 360 | 79.3 |

PRESSURE SYSTEM INSTALLATION

When a submersible pump is to be used as a pressure system, the following items are required.

A pressure tank of at least 30 litres draw off. A pressure switch, which is available from White International in a kit complete with pressure gauge and 3 way tee piece which allows plumbing to the pressure tank. A non-return valve at the top of the bore in addition to the pump's in-built non-return valve is required for pressure system application. It is recommended to install an additional gate valve (isolating valve) to allow blow down of the pressure tank to facilitate pressure pre-charge checking.

The 2 pole pressure switch supplied with the kit may be used to break the supply to the control box on single phase pumps up to 1.5 hp. A starter contactor must be used in addition to the control box for single phase pumps above 1.5 hp, and all three phase pumps. One pole of the pressure switch supplied should be used to switch the control circuit of the starter contactor.

The pressure tank connected must be large enough to provide the storage capacity and draw off to limit pump starts to 5 per hour. Use more than one tank if necessary. Do not use "air volume control" tanks from old model pressure systems or primitive non-diaphragm type tanks.

CAUTION: *If the available pump pressure at the bore head can exceed the pressure tank's maximum working pressure should there be a pressure switch failure, then a pressure relief valve should be fitted in the delivery line to prevent the tank being over pressurised. Use only nominal 30 litre draw off tanks or larger. Do not at any time use smaller tanks. If cut out pressures exceed 5 bar (500 kPa, 73 psi) fit a 12 bar switch. Pressure switches operated outside their design working range can fatigue and cause pump and fittings failures and void warranty.*

PUMP SERVICE CHART

| THE TROUBLE IS? | WHAT TO LOOK FOR |
|---|---|
| Overload protector trips | Faulty pressure switch Control box in sun or near heat source Wrong control box being used Defective control box Hydraulic overload Water logged pressure tank Low voltage supply to motor Excessive motor starts |
| No water delivered | Broken pump shaft or coupling Check valve installed backwards Check valve stuck closed Inlet screen clogged Water level too low in well Hole in delivery pipe below top of bore |
| Low water delivery | Fittings stopping check valve opening fully Pump rotation backwards Water level too low in well Discharge pipe clogged, corroded or ruptured Pump installed too low in well and covered with sand or other solids Inlet screen partial clogged Worn pump Leak in outlet pipe below top of bore Check valve stuck partially closed |
| Pump doesn't shut off | Pipe ruptured Defective or improperly adjusted pressure switch Water level too deep for pump. Check selection Pump is air or gas bound Worn pump Pipe obstruction Pump needs adjusting |
| Pump starts and stops too often (i.e. more than 5 per hour) | Incorrect pressure switch, see pressure system installation Defective air valve or tank diaphragm Pressure switch differential adjustment failure Pressure tank is too small |

PUMP SERVICE CHART con't.

| THE TROUBLE IS? | WHAT TO LOOK FOR |
|--|---|
| Fuses blow but overload doesn't trip | Supply cable too small Hydraulic overload Fuses too small Fuse receptacle dirty or corroded Power spike Loose connection in fuse box Defective incoming power leads Excessive motor starts per hour Earth wire connected to wrong control box terminal Cable insulation failure Voltage too high or low |
| Electric shock from water pipe Note: A motor down to earth or defective cable will not cause a shock. | Defective (grounded) incoming power leads Defective control box Earth wire connected to wrong control box terminal |
| Pressure gauge oscillates, flow surges (snoring) | Water level too low in the well. (Flow through pump greater than flow into well) |
| Electrolysis on motor and pump | Insufficient earth / earth leakage Broken earth wire |

NOTE: Always install borehole submersibles with ON/OFF switches and approved circuit breaker to protect against motor damage and electrocution.

